

Electric Technology Discussion, integration to the Waste Industry





CITY OF NEW YORK
DEPARTMENT OF
SANITATION
TRAFFIC

- **Why would you be interested having Electric truck as part of your fleet?**
- **What are the Pros and Cons of making a change towards EV?**
- **Why now?**

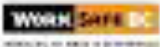

How Loud Is It?

Waste Management

Note: are some typical Waste Management noise levels. Note: these are examples only and may not apply to your specific location. Noise-induced hearing loss results from a combination of high sound levels and extended periods of exposure to sounds above 85 dBA. Protect your hearing when performing these jobs.

L. Noise Ex.
 Working on a
 15 ton lift
 Garbage Truck
 (includes
 Garbage Truck
 (includes
 Exhaust Garb
 (includes
 Snow Truck



100-110dB
 Exhaust from
 ing engine
 truck
 protection
 full
 out of the job

The following
 exposures:

Truck Driver	85-90 dBA
Glass Bottle Manufacturing	85-90 dBA
Hammermill	110 dBA
Steel Recycling	95 dBA
Paper Recycling	95-100 dBA
Transfer	85-90 dBA
Street Maintenance	85-100 dBA
Street Paving	100 dBA

Noise Exposure	Recommended OPO
Less than 90 dBA	Class C, Grade 1
Less than 95	Class B, Grade 2
Less than 100	Class A, Grade 3
Less than 105	Class A, Grade 4
Less than 110	Earplugs + Formals



© National Compensation Board of British Columbia



Out of control
fuel cost



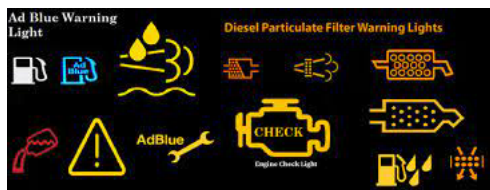
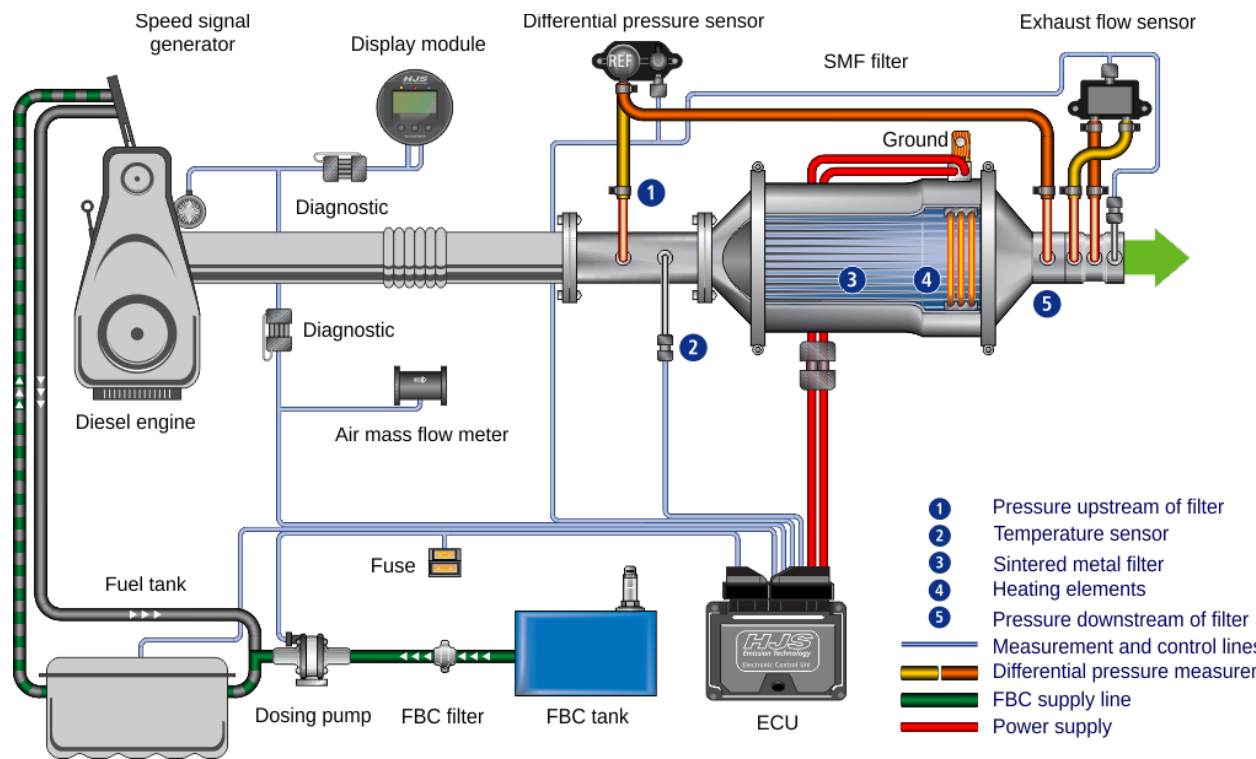
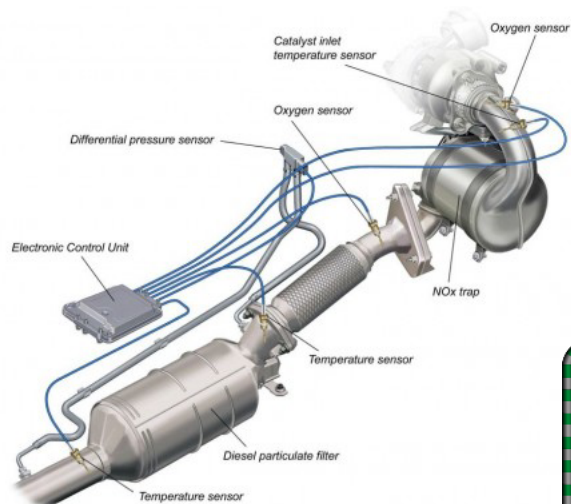



Current Rollins/Mack demo truck Statistics

- 448hp with 4051 LB-FT
- 376 KW Battery Pack (Teir 2)
- 2 Speed Transmission
- 160 KM Range- 800 homes 8 hours without recharge
- 100% charge in 90 minutes with 150KW charger

2023 EV Summit hosted by BCTA

Minister of transportation – Bruce Ralston
Minister of Energy – Rob Fleming





Main Stream Chassis manufactures see the ROI in the development of EV for Refuse

MACK-Freightliner-Peterbilt-Autocar and many others



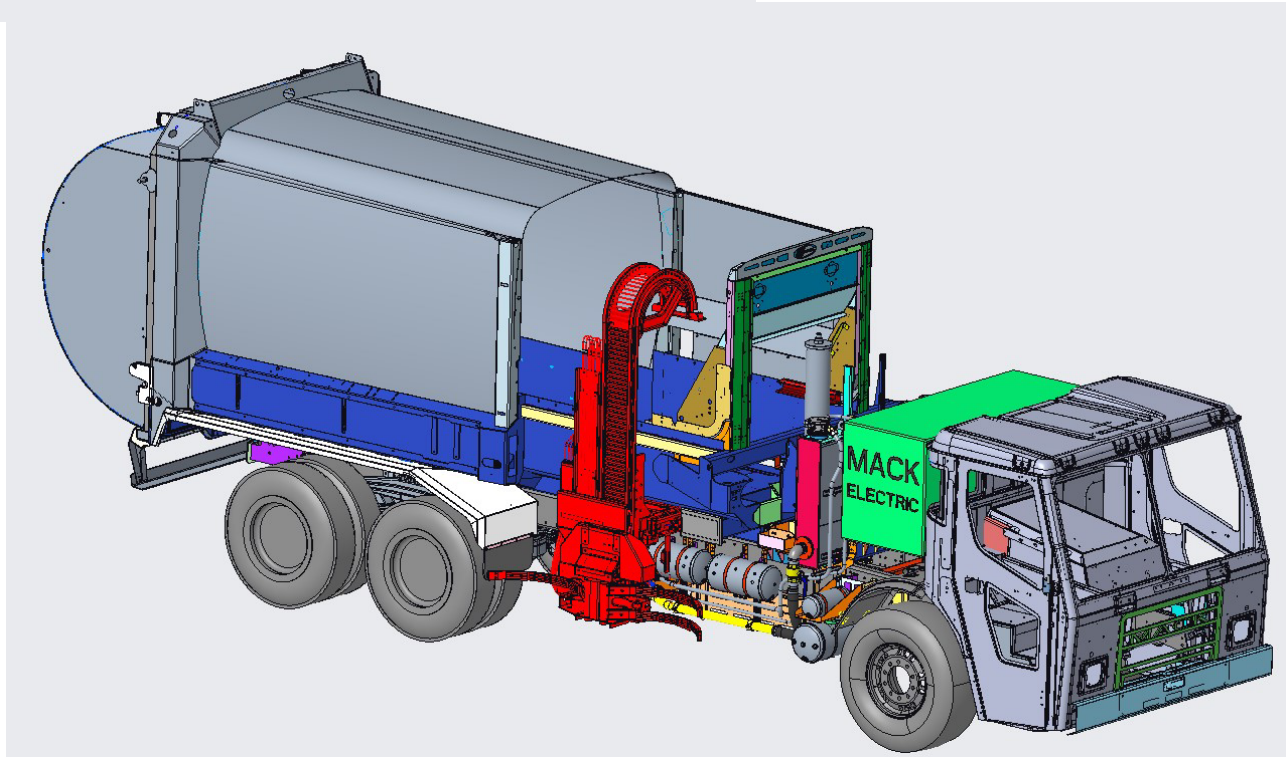
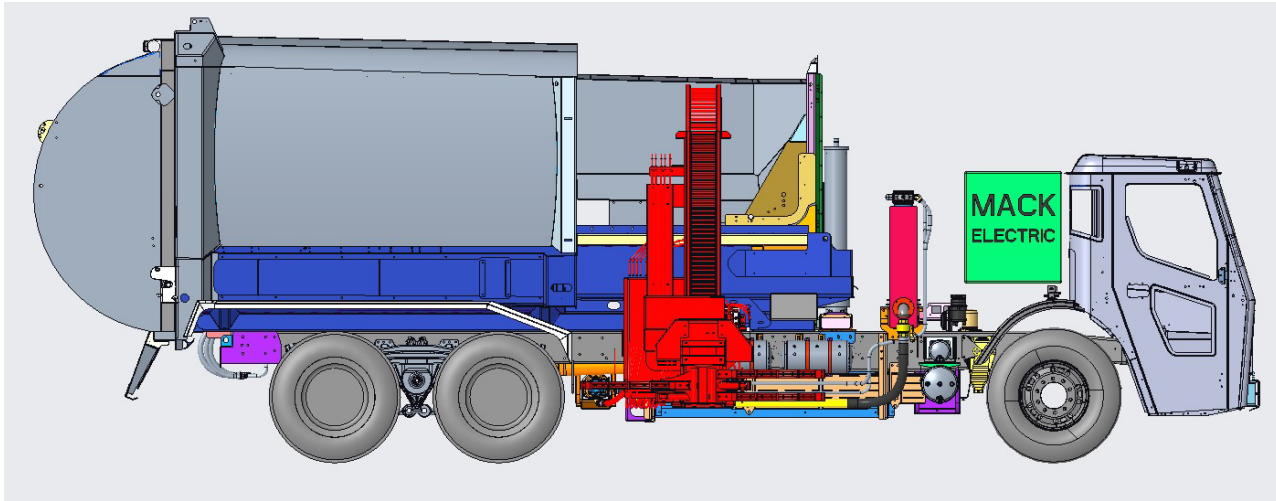



Electromobility and Refuse

GREAT FIT FOR MANY REFUSE APPLICATIONS

Why Refuse?

- Closed loop operation on predetermined routes
- Return home every night
- Start/Stop nature allows for regenerative braking opportunities to recapture energy

MAG
ELECTR



Challenges to Consider

- Acquisition Cost
- Energy Required For Charging
- Routing Concerns with Overall Travel Requirements
- Weather Issues: Effects of Extreme Cold, Operator Environment, Heat, Air Conditioning



Summary

- EV technology has advanced to be a viable option within a collection fleet
- Routing will be a key consideration and travel to transfer station
- Power to your facility will have a bearing on if and how many would be practical
- Consider as supplement to your fleet rather than your complete fleet at this time
- Do an ROI using your current maintainance, fuel verses energy cost , Acquisition cost verses diesel trucks, net after government rebate.
- Current rebates, infrastructure funding, \$100K Provincial government, \$150K Federal goverment

- Cities positive feedback from the public for moving in a greener direction. Most cities have mandates to buy electric
- Contractors, how would you leverage running some EV trucks to grow your businesss with residences and your municipal customers.

Thank You

